

# Design and Heat Transfer Enhancement of Heat Sink by Natural Convection

V. Ashok Kumar<sup>1</sup>, K. Manoj<sup>2</sup>, Md. Ejaz Khan<sup>3</sup>

Associate Professor, Mechanical Engineering, Mother Theresa College of Engg & Tech, Peddapalli, Telengana<sup>1</sup>

M.Tech, Student, Mechanical Engineering, Mother Theresa College of Engg & Tech, Peddapalli, Telengana<sup>2</sup>

Assistant Professor, Mechanical Engineering, Mother Theresa College of Engg & Tech, Peddapalli, Telengana<sup>3</sup>

**Abstract:** In this thesis, investigations will be carried out to determine the heat transfer rates in a heat sink by means of varying pitch of the fin with air and helium as the working fluids. Analysis is carried out for heat sink with closed and open enclosure constant wall heat flux and different mass flow rates calculated for Reynolds number 8000, 10000, 12000 and 14000 different pitch 2mm and 4mm. CFD analysis is performed for different cases to determine heat transfer coefficient, pressure drop, mass flow rate and heat transfer rate. Thermal analysis is to determine heat flux and temperature distribution by with different aluminum alloys (aluminum alloy, aluminum alloy 7075). 3D modeling is done in PRO-Engineer. Analysis is performed in ANSYS software.

**Keywords:** Finite element analysis, heat sink, CFD analysis, thermal analysis.

## I. INTRODUCTION

**Heat sink:** A heat sink transfers thermal energy from a higher temperature device to a lower temperature fluid medium. The fluid medium is frequently air, but can also be water, refrigerants or oil. If the fluid medium is water, the heat sink is frequently called a cold plate. In thermo dynamics a heat sink is a heat reservoir that can absorb an arbitrary amount of heat without significantly changing temperature. Practical heat sinks for electronic devices must have a temperature higher than the surroundings to transfer heat by convection, radiation, and conduction. A heat sink is a passive heat exchanger that transfers the heat generated by an electronic or a mechanical device to a fluid medium, often air or a liquid coolant, where it is dissipated away from the device, thereby allowing regulation of the device's temperature at optimal levels.

device or component will depend on the thermal resistance from the component to the environment, and the heat dissipated by the component. To ensure that the component temperature does not overheat, a thermal engineer seeks to find an efficient heat transfer path from the device to the environment.

### ADVANTAGES OF HEAT SINK

- dissipate more heat than conventional heat sinks with the same footprint
- reduce heat sink and overall system volume
- increase the aluminum extrusion cooling surface area by two to three times
- Thermoelectric modules
- uninterruptable power supplies
- variable speed motor controls
- ac welding switches
- power rectification equipment
- laser power supplies
- traction drives

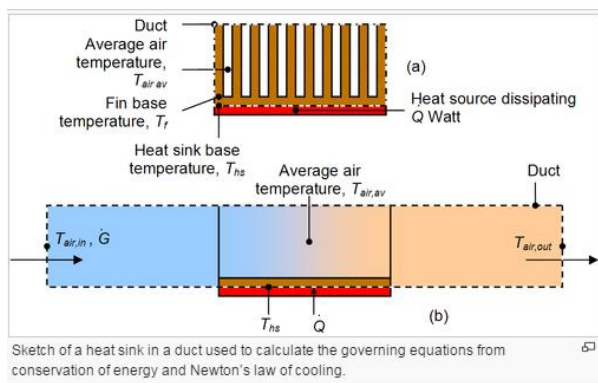

Fig1. Heat sink

### Applications of heat sink:

#### Microprocessor cooling

Heat dissipation is an unavoidable by-product of electronic devices and circuits. In general, the temperature of the

## II. LITERATURE REVIEW

A comprehensive theoretical and experimental study was carried out on the thermal performance of a pin fin heat sink. An experimental model was shown that has the capability of predicting influence of effective surface area of pin fin on thermal heat transfer coefficient. Pin fin arrays are used in many applications to enhance heat transfer and also show enhancement of heat transfer coefficient for different material of fin. Several different types of experiment tests were run out with corresponding variations including the material of pin fin and different perforations on pin fin. Perforations with circular cross-section are along

the height of pin fin and there number varies from 1 to 3. The result indicates that the material having higher thermal conductivity with higher number of perforation gives more heat transfer coefficient. The effect of perforation on heat transfer was investigated.

**III. PROBLEM DESCRIPTION**

Investigations will be carried out to determine the heat transfer rates in a heat sink by means of varying pitch of the fin with air and helium as the working fluids. Analysis is carried out for heat sink with closed and open enclosure constant wall heat flux and different mass flow rates calculated for Reynolds number 8000, 10000, 12000 and 14000 different pitch 2mm and 4mm. temperature distribution by with different aluminum alloys (aluminum alloy, aluminum alloy 7075).

**IV. INTRODUCTION TO CAD/CAE**

**Computer-aided design (CAD)**, also known as **computer-aided design and drafting (CADD)**, is the use of computer technology for the process of design and design-documentation.

**INTRODUCTION TO PRO-ENGINEER**

Pro/ENGINEER Wildfire is the standard in 3D product design, featuring industry-leading productivity tools that promote best practices in design while ensuring compliance with your industry and company standards. Integrated Pro/ENGINEER CAD/CAM/CAE solutions allow you to design faster than ever, while maximizing innovation and quality to ultimately create exceptional products.

**Different modules in pro/engineer**

Part design, Assembly, Drawing & Sheet metal.

**INTRODUCTION TO FINITE ELEMENT METHOD:**

Finite Element Method (FEM) is also called as Finite Element Analysis (FEA). Finite Element Method is a basic analysis technique for resolving and substituting complicated problems by simpler ones, obtaining approximate solutions Finite element method being a flexible tool is used in various industries to solve several practical engineering problems. In finite element method it is feasible to generate the relative results.

**V. RESULTS AND DISCUSSIONS**

**Models of heat sink using pro-e wildfire 5.0:**

**PRO-E 3D MODELS  
HEAT SINK 3D MODELS**

Heat sink base height	4mm
Fin height	24, 48mm
Pitch	2mm, 4mm

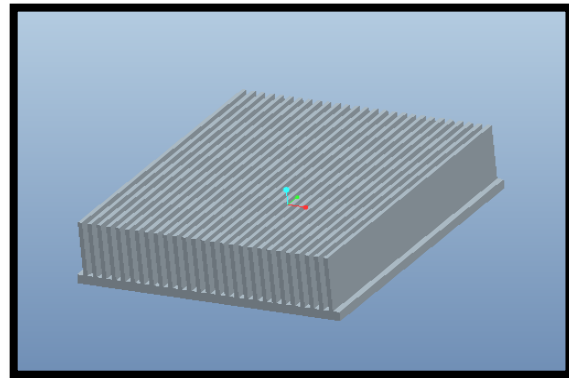

Fig: 2pitch2; height 24

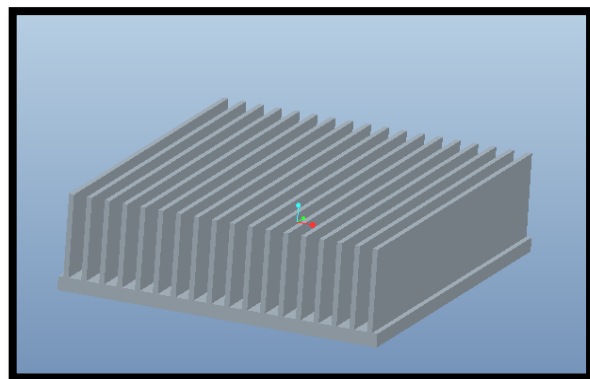

Fig: 3 pitch4; height 24

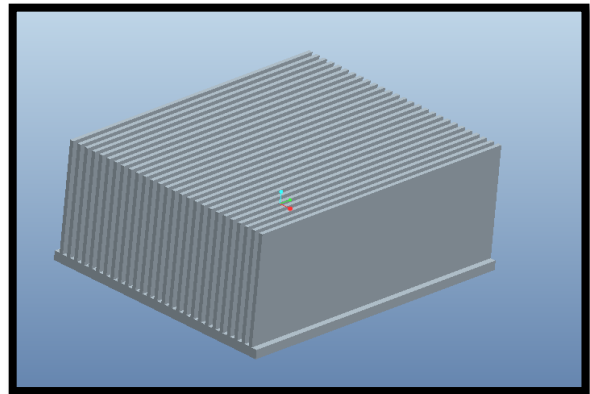

Fig: 4 pitch2; height48

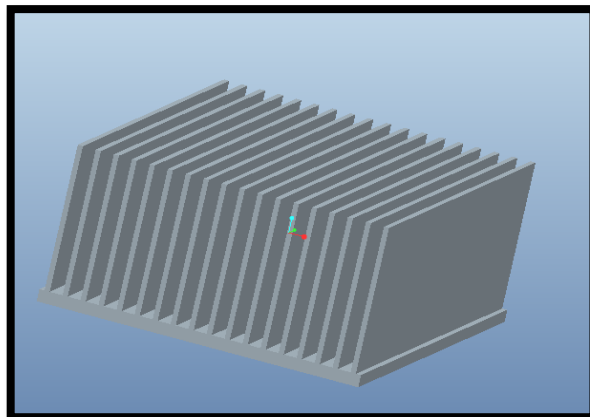

Fig: 5 pitch4; height 48

**2D DRAWINGS OF HEAT SINK PITCH2; HEIGHT 24**

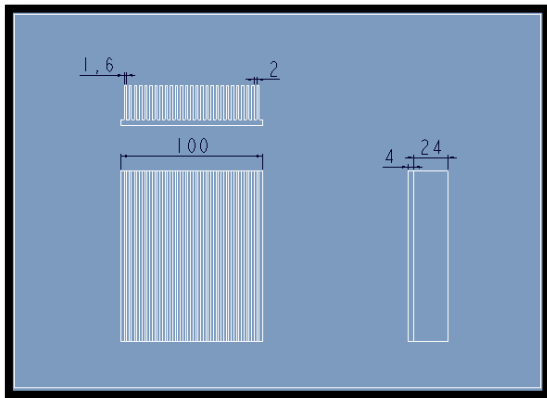

Fig: 6 pitch2; height 24

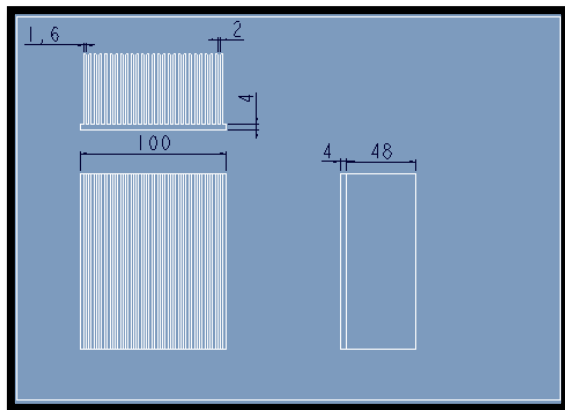

Fig:7 pitch4; height 24

**V. VELOCITY CALCULATIONS**

**FOR REYNOLDS NUMBER 8000 – 14000**

**Reynolds number – 8000**

$$Re = \rho v L / \mu$$

$\rho$  = density kg/s  
 $v$  = velocity m/s  
 $L$  = length of the tube (mm)  
 $\mu$  = viscosity kg/ms

$$Re = \frac{\rho \times v \times L}{\mu}$$

Fin Height = 24

$$8000 = \frac{1.225 \times v \times 24}{1.7894 \times 10^{-5}}$$

$v = 4.86911 \text{ m/s}$

Fin Height = 48

$$8000 = \frac{1.225 \times v \times 48}{1.7894 \times 10^{-5}}$$

$v = 2.43455 \text{ m/s}$

**Reynolds number – 10000**

Fin Height = 24

$$10000 = \frac{1.225 \times v \times 24}{1.7894 \times 10^{-5}}$$

$v = 6.08639 \text{ m/s}$

Fin Height = 48

$$10000 = \frac{1.225 \times v \times 48}{1.7894 \times 10^{-5}}$$

$v = 3.04319 \text{ m/s}$

**Reynolds number – 12000**

Fin Height = 24

$$12000 = \frac{1.225 \times v \times 24}{1.7894 \times 10^{-5}}$$

$v = 7.30367 \text{ m/s}$

Fin Height = 48

$$12000 = \frac{1.225 \times v \times 48}{1.7894 \times 10^{-5}}$$

$v = 3.04319 \text{ m/s}$

**Reynolds number – 14000**

Fin Height = 24

$$14000 = \frac{1.225 \times v \times 24}{1.7894 \times 10^{-5}}$$

$v = 8.52095 \text{ m/s}$

Fin Height = 48

$$14000 = \frac{1.225 \times v \times 48}{1.7894 \times 10^{-5}}$$

$v = 4.26047 \text{ m/s}$

**CFD ANALYSIS OF HEAT SINK WITH CLOSED ENCLOSURE**

**FLUID -AIR PITCH2; HEIGHT 24**

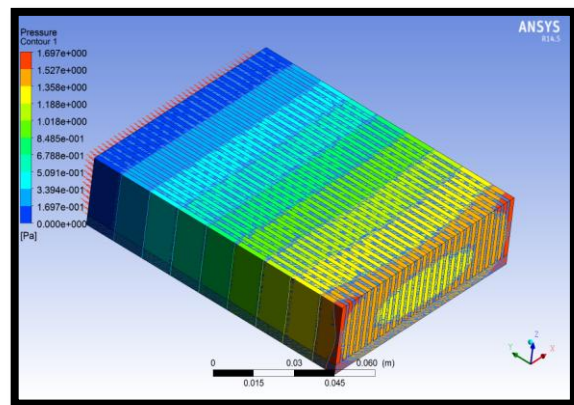

Fig: 8 Pressure

According to the above contour plot, the maximum static pressure one end of the fins because the applying the boundary conditions at inlet of the closed enclosure one end surface and minimum static pressure at the other end of the fins. According to the above contour plot, the maximum pressure is 1.697e+00Pa and minimum static pressure is 1.697e-001e+01Pa

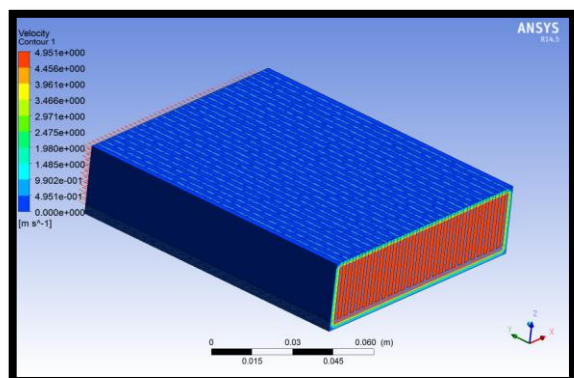

Fig: 9 velocity

According to the above contour plot, the maximum velocity magnitude inside between fins at one end of the tubes because the applying the boundary conditions at inlet of the closed enclosure one end surface and minimum velocity magnitude at the outer surface of the fins. According to the above contour plot, the maximum velocity is  $4.951e+000$  and minimum velocity magnitude is  $4.951e-001$

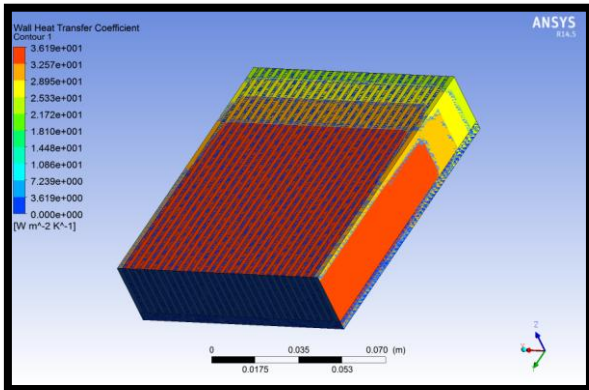

Fig: 10 Heat transfer coefficient

According to the above contour plot, the maximum heat transfer coefficient of the heat sink at half of the heat sink from one end and minimum heat transfer coefficient another end of the heat sink. According to the above contour plot, the maximum heat transfer coefficient is  $3.619e+001 \text{ w/m}^2\text{-k}$  and minimum heat transfer coefficient is  $3.619e+000 \text{ w/m}^2\text{-k}$ .

**MASS FLOW RATE**

Mass Flow Rate	(kg/s)
inlet	0.016676579
interior-____msbr	0
interior-solid	-0.85049272
outlet	-0.016676083
wall-____msbr	0
wall-solid	0
-----	-----
Net	4.9546361e-07

**HEAT TRANSFER RATE**

Total Heat Transfer Rate	(w)
inlet	1256.3077
outlet	-1195.5676
wall-____msbr	0
wall-solid	-61.252232
-----	-----
Net	-0.51211929

**5.4. THERMAL ANALYSIS OF HEAT SINK MATERIALS- ALUMINUM ALLOY &ALUMINUM ALLOY 7075**

**PITCH2; HEIGHT 24 MATERIAL- ALUMINUM ALLOY**

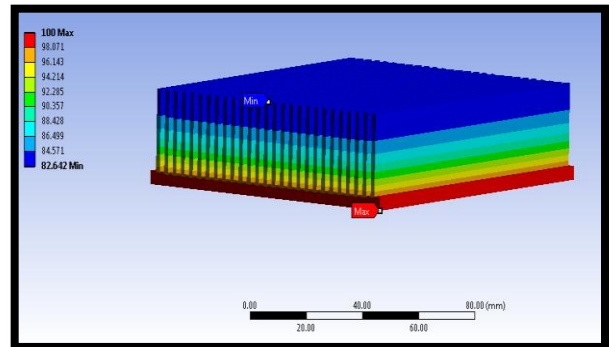

Fig 11 temperature

According to the contour plot, the temperature distribution maximum temperature at base plate of the heat sink. We applied the temperature bottom surface of the heat sink base plate and applied convection to fins. Then the maximum temperature at bottom surface of the heat sink base plate and minimum temperature at end of the fins.

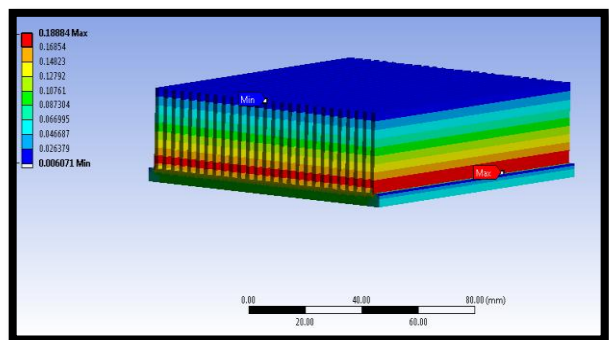

Fig: 12 heat flux

According to the contour plot, the maximum heat flux at starting portion of the heat sink fins. We applied the temperature bottom surface of the heat sink base plate and applied convection to fins. Then the maximum heat flux at starting portion of the heat sink fins and minimum heat flux at end of the fins. According to the above contour plot, the maximum heat flux is  $0.18884 \text{ w/mm}^2$  and minimum heat flux is  $0.006071 \text{ w/mm}^2$ .

**VI. RESULTS AND DISCUSSIONS**

**THERMAL ANALYSIS RESULT TABLE**

models	materials	Temperature(°C)		Heat flux(w/mm <sup>2</sup> )
		Max.	Min.	
Pitch 2; height 24	Aluminum alloy	100	82.642	0.18884
	Aluminum alloy 7075	100	83.469	0.19042
Pitch 4; height 24	Aluminum alloy	100	82.979	0.18102
	Aluminum alloy 7075	100	83.79	0.18963
Pitch 2; height 48	Aluminum alloy	100	57.698	0.27751
	Aluminum alloy 7075	100	59.463	0.28446
Pitch 4; height 48	Aluminum alloy	100	57.996	0.27863
	Aluminum alloy 7075	100	59.755	0.28555

CFD ANALYSIS RESULT TABLE

models	Reynolds numbers	Pressure (Pa)	Velocity (m/s)	Heat transfer coefficient (w/mm <sup>2</sup> -k)	Mass flow rate(kg/s)	Heat transfer rate(w)
Pitch 2; height 24	8000	1.697e+000	4.951e+000	3.619e+001	4.9546e-07	0.51211929
	10000	2.566e+000	6.195e+000	4.323e+001	4.7869e-07	0.55114746
	12000	3.568e+000	7.431e+000	4.977e+001	5.79282e-07	0.57193756
	14000	4.678e+000	8.667e+000	5.600e+001	4.56348e-07	0.61563873
Pitch 4; height 24	8000	1.703e+000	4.958e+000	3.624e+001	6.3888e-07	0.045654
	10000	2.569e+000	6.192e+000	4.323e+001	4.00468e-07	0.023071289
	12000	3.557e+000	7.431e+000	4.900e+001	4.88013e-07	0.0388183
	14000	4.677e+000	8.666e+000	5.600e+001	4.52622e-07	0.0292968
Pitch 2; height 48	8000	3.956e-001	2.470e+000	3.025e+001	2.309097e-06	0.18188477
	10000	5.339e-001	3.082e+000	3.025e+001	2.209097e-06	0.010864258
	12000	7.536e-001	3.697e+000	3.025e+001	5.7742e-08	0.0023193359
	14000	9.532e-001	4.313e+000	3.232e+001	2.421438e-07	0.028442383
Pitch 4; height 48	8000	4.117e-001	2.47e+000	2.048e+001	9.8995e-07	0.067993164
	10000	5.311e-001	3.083e+000	2.422e+001	1.27218e-06	0.079589844
	12000	7.321e-001	3.697e+000	2.839e+001	2.22399e-06	0.15661621
	14000	9.531e-001	4.313e+000	3.232e+00	1.508742e-07	0.023071284

Mass flow rate plot

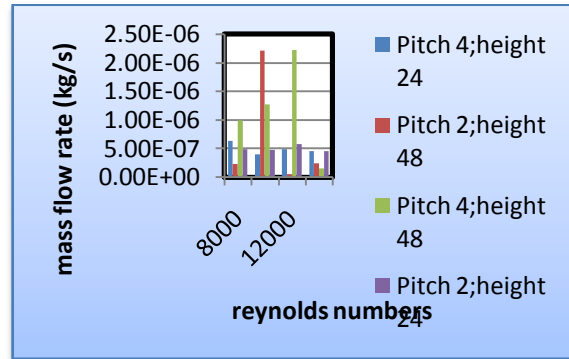

Heat transfer rate plot

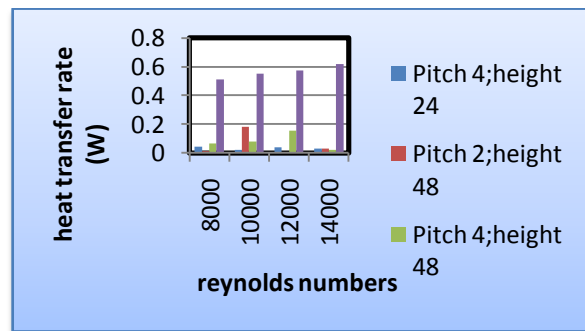

GRAPHS

Pressure plot

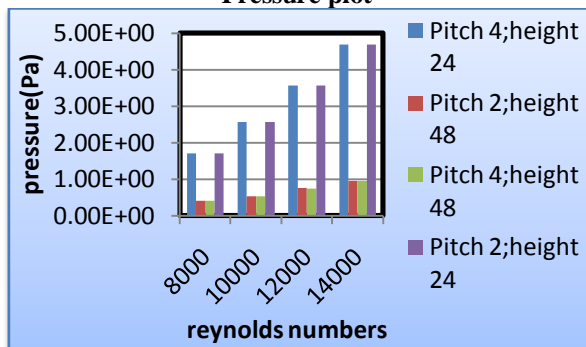

Velocity plot

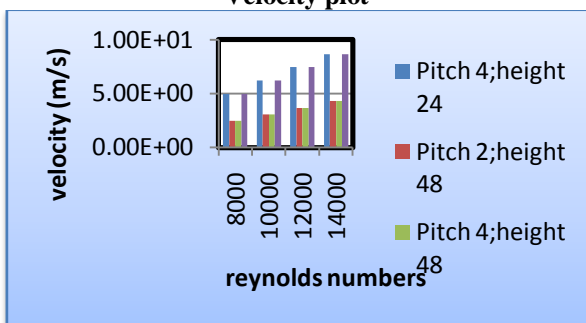

Thermal flux plot

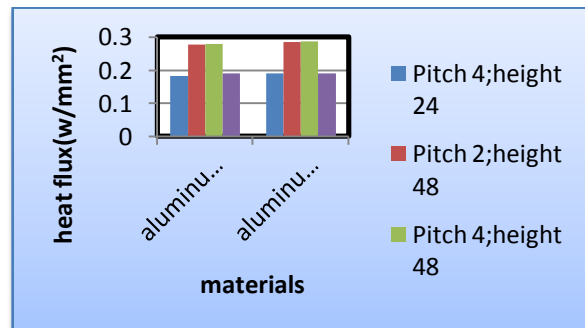

Heat transfer coefficient plot

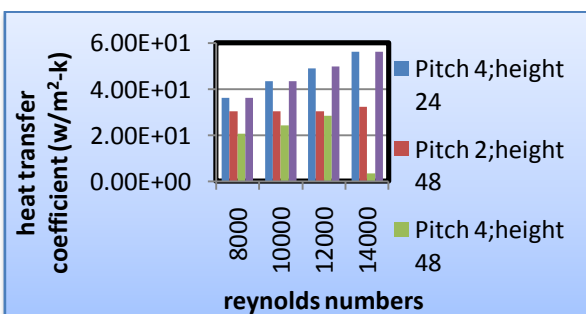

VII. CONCLUSION

Thermal analysis is to determine heat flux and temperature distribution by with different aluminum alloys (\aluminum alloy, 7075). By observing the CFD Analysis the heat transfer rate and mass flow rate are increases by increasing the Reynolds number and more heat transfer rate for pitch2 mm and height 24mm heat sink. By observing the thermal analysis the heat flux value more for aluminum alloy 7075 material. So we conclude the aluminum alloy 7075 material is better for heat sink.

REFERENCES

[1] Padmakar A. Deshmukh, Kamlesh A. Sorate and Ravi Warkhedkar, "Modeling and Analysis of Rectangular Fin Heat Sinks under Natural Convection for Electronic Cooling", International Journal of Engineering Research and Technology, ISSN 0974-3154 Volume 4, Number 1, pp 67-74, (2011).

- [2] Mobedi M., Sunden B., "Natural Convection Heat Transfer from a Thermal Heat Source Located in a Vertical Plate Fin", *International Communications in Heat and Mass Transfer* 33, 943-950, (2006).
- [3] Jan Bijanpourian," Experimental determination of the thermal performance of a free standing fin Structure copper heatsink", Dept. of Public Technology, Mälardalen University, MdH
- [4] MassimilianoRizzi, Marco Canino, Kunzhong Hu, Stanley Jones, Vladimir Travkin, Ivan Catton, "Experimental Investigation of Pin Fin Heat Sink Effectiveness", MAE Department, 48-121 Engineering IV, UCLA, Los Angeles, CA 90024-1597
- [5] Starner K.E. and McManus H.N., "An Experimental Investigation of Free Convection Heat Transfer from Rectangular Fin Arrays", *Journal of Heat Transfer*, 273-278, (1963).
- [6] Leung C.W., Prober S.D. and Shilston M.J. "Heat Exchanger: Optimal Separation for Vertical Rectangular Fins Protruding from a Vertical Rectangular Base", *Applied Energy*, 77-85, (1985).
- [7] Harahap F., Lesmana H., Dirgayasa A.S., "Measurements of Heat Dissipation from Miniaturized Vertical Rectangular Fin Arrays under Dominant Natural Convection Conditions", *Heat and Mass Transfer* 42, 1025-1036, (2006).
- [8] Yalcin H.G., Baskaya S., Sivrioglu M., "Numerical Analysis of Natural Convection Heat Transfer from Rectangular Shrouded Fin Arrays on a Horizontal Surface", *International Communications in Heat and Mass Transfer* 35, 299-311, (2008).
- [9] Yüncü H. and Mobedi M., "A Three Dimensional Numerical Study on Natural Convection Heat Transfer from Short Horizontal Rectangular Fin Array", *Heat and Mass Transfer* 39, 267-275, (2003).
- [10] Kundu B., Das P.K., "Performance and Optimum Design Analysis of Convective Fin Arrays Attached to Flat and Curved Primary Surfaces", *International Journal of Refrigeration*, 1-14, (2008).